

# ZONE SMART LIFT

## SL 780 Outdoor Giant



The SL 780 Outdoor Giant handles almost a tonne.



Automated load safety system with audible and visual alarm

## SL 780 Outdoor Giant

### MRC is 950 kgs

- Off road with front wheel drive
- Manoeuvrable with dual rear wheels
- Puncture proof balloon tyres
- Electric brakes
- Lifting height 4500mm from center of yoke
- Dual vacuum circuits and pumps
- 4 suction pads 400mm each & 2 Vacuum pads 300mm each (fully adjustable)
- Silicone vacuum pads (non marking)
- Vacuum pad covers
- Variable speed travel controls with high/low
- Multifunctional rotating head
- Wireless remote control for all hydraulic functions
- Ergonomic operational handle
- Easily transported on a trailer or in a van
- Telescopic boom
- 100mm side shift
- Operators Manual
- Risk assessment
- NDT Certificate for lifting lugs
- Workshop tested by Zone Group

Authorised Australian Distributor of

**Smart Lift**  
DENMARK

**T** +61 (0) 8 9459 8214  
**E** info@zoneg.com.au  
**W** www.zoneg.com.au

113 Victoria Road, Kenwick, WA 6107

**ZONE**  
GROUP

# ZONE SMART LIFT

## SL 780 Outdoor Giant

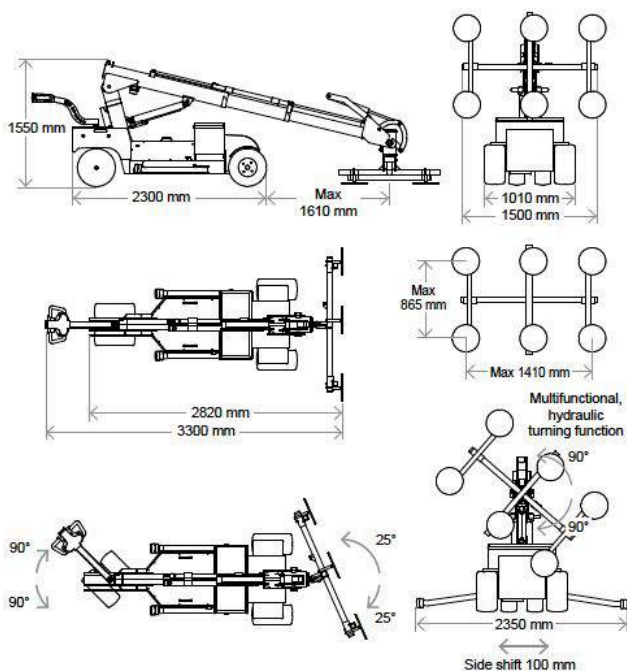
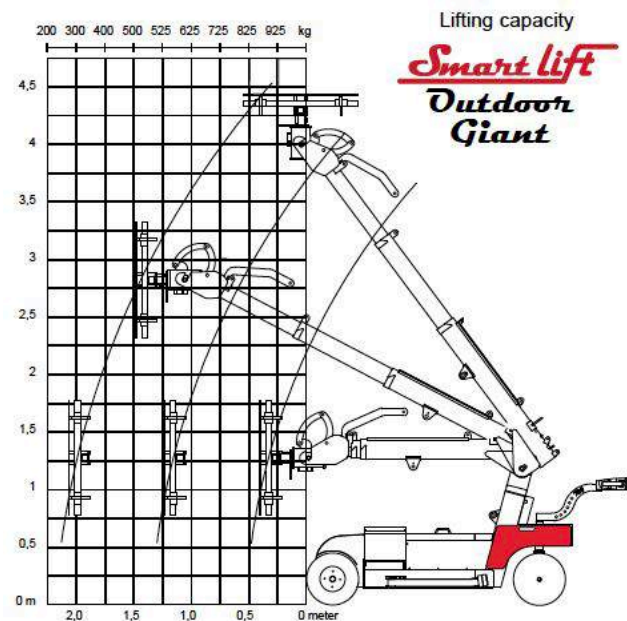

Silicone Anti Marking Vacuum Pads



The Smart Lift has hydraulic movements in all directions. The multifunctional, hydraulic rotary head.

### TECHNICAL DATA

Description	Value
Total weight	1300 kg
Total height	1550 mm
Total width (min)	1010 mm
Total length (min)	2820 mm
Telescoping of arm	2 x 830 mm
Speed regulation	Stepless high/low
Side shift	100 mm
Vacuum system 2	circuits
Lifting height, ceiling installation	4400 mm
Charging voltage	230 volt
Integrated charger	
Charging time 25-100%	Approx 10 hours
Batteries (4 x 12 v) 24 volt	4 x 134 A AGM
Running period	Approx 8 hours
Frontwheel drive	2000 Watt-AC
Brake	Electric
Suctions pads	4 x Ø 400 mm and 2 x Ø 300 mm
Automatic suction	2 vacuum pumps
Lifting capacity, telescopic arm in/extended	825 kg / 270 kg



Authorised Australian Distributor of

**Smart Lift**  
DENMARK

T +61 (0) 8 9459 8214  
E info@zoneg.com.au  
W www.zoneg.com.au

113 Victoria Road, Kenwick, WA 6107

**ZONE**  
GROUP